

Chicago Plastic Systems No Loss Stack

There is a maximum of 8" between gussets
 The cone top and cylindrical body are joined
 to the legs via welds.
 Sizes larger than 24" are rolled from type two PVC.

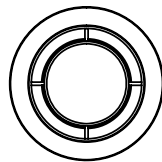

Specifications		
Duct Size	No. Gussets	Flange
6	4	none
7	4	none
8	4	none
9	4	none
10	4	none
12	6	none
14	6	none
16	8	none
18	8	none
20	8	1 1/2" angle
22	10	1 1/2" angle
24	10	2" angle
26	12	2" angle
28	12	2" angle
30	12	2" angle
32	14	2" angle
34	14	2" angle
36	16	2" angle
38	16	2" angle
40	16	2" angle

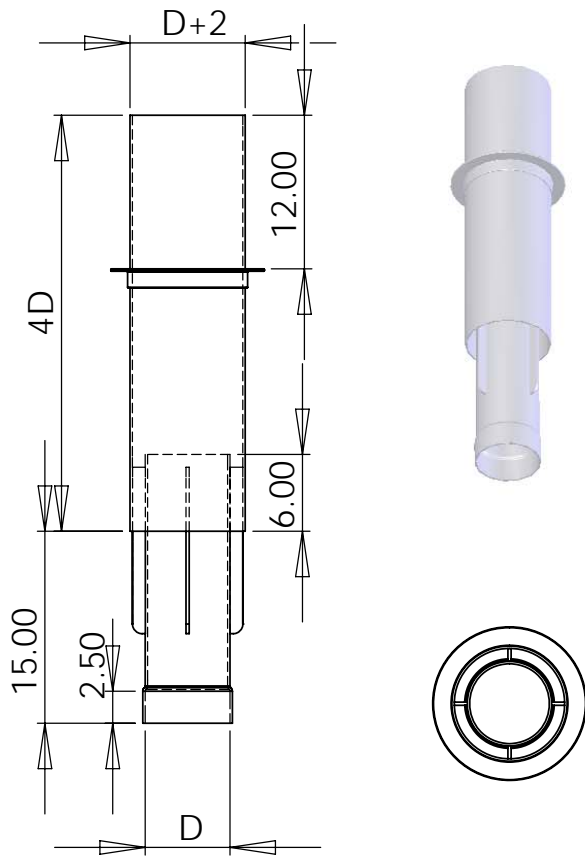
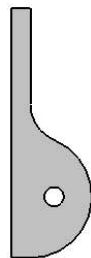

*Optional gusset for guy wire support

PVC Classes 12454-B&C per ASTM D-1784-92
 (Formerly known as Type I, Grades 1&2)